

An Analysis of the Heavy Rain Event:

Thunder Bay , May 28, 2012

Graham Saunders
Weather Works

Outline

- Weather conditions of evening of May 27
- Summary of heavy rain event – May 28
- Antecedent moisture conditions and overland flow
- 50 -100-year events (IDF curves)
- Rainfall measurement: potential errors
- Historical Storms
- CIMA Report
- Discussion

Weather conditions late evening on May 27

A low-pressure system and associated warm front moved from western Minnesota to southwest of Thunder Bay.

Environment Canada Forecast at 4 PM

SUNDAY 27 MAY 2012

TONIGHT..SHOWERS WITH RISK OF A
THUNDERSTORM. AMOUNT 10 TO 15 MM . . .

Surface analysis: May 27 at 2000 (8 p.m.)

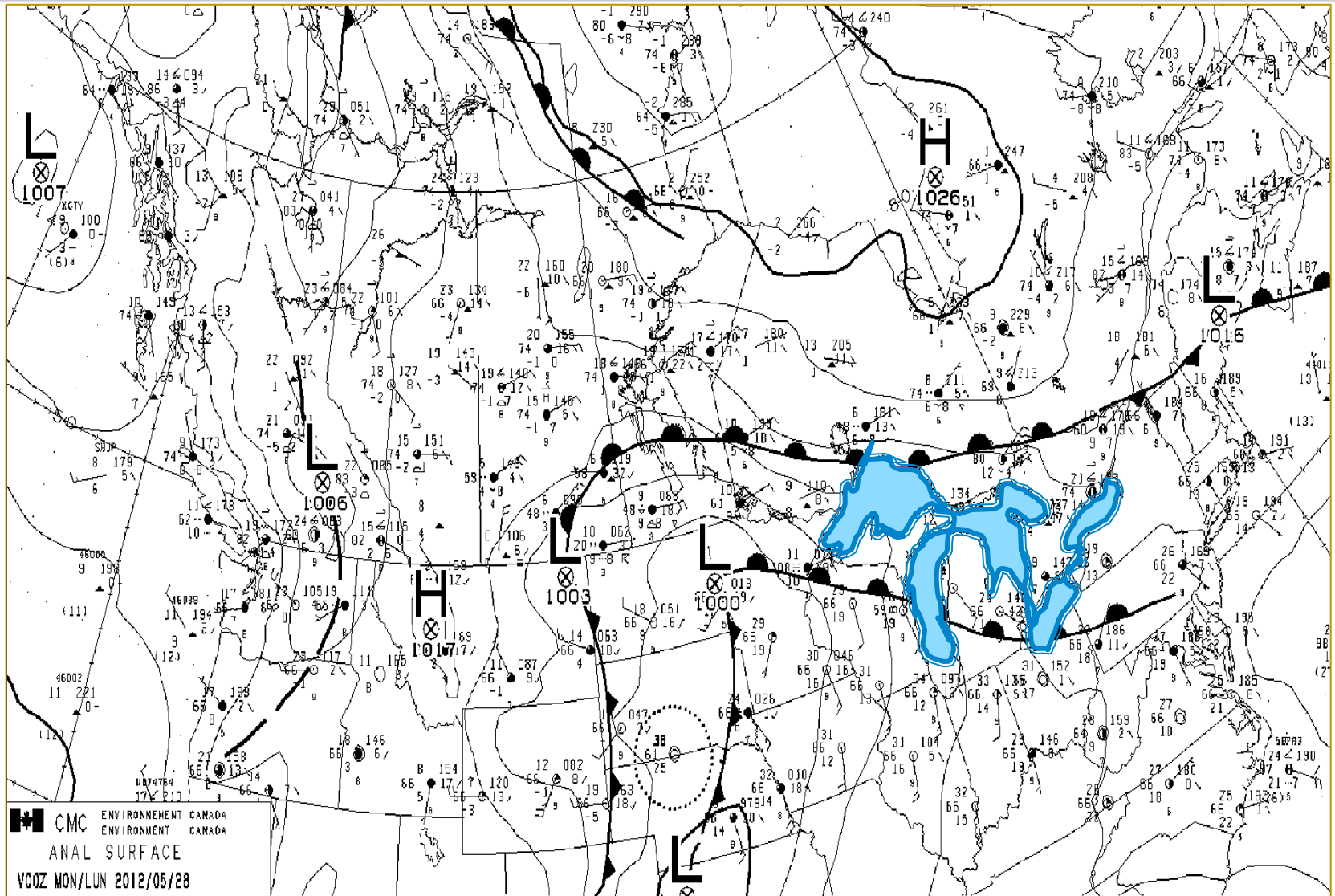

Surface Analysis: May 27 at 2015 (8:15 p.m.)

Surface Map

0015Z 28 MAY 12

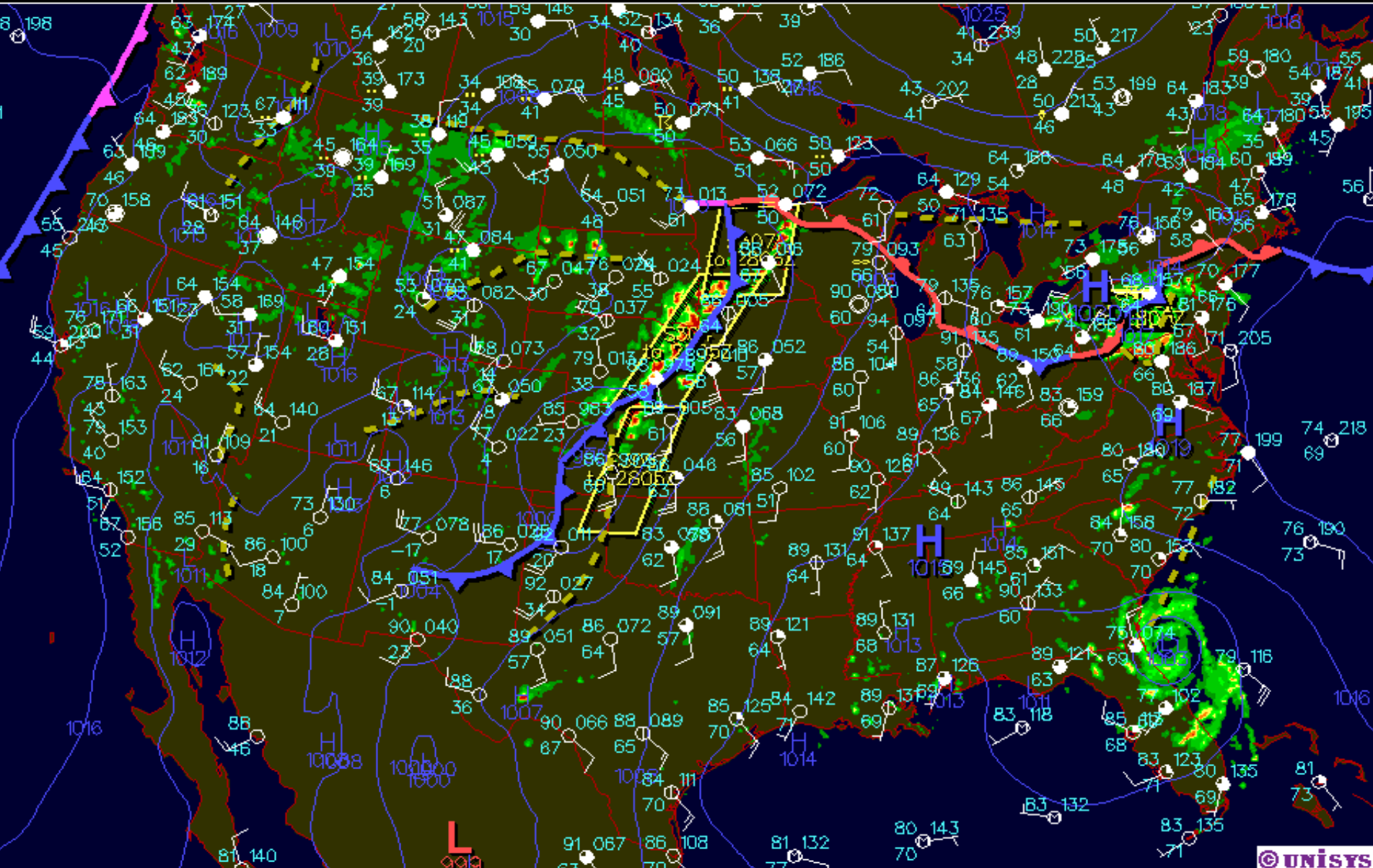

Defining Rain Events

Light rain: to 2.5 mm per hour

Moderate rain: 2.6 mm to 7.5 mm per hour

Heavy rain: more than 7 mm per hour

≥ 50 mm in 24 hours = a **heavy rain day**

Some Rain Statistics for Thunder Bay – May 28, 2012

Rain began in Thunder Bay on May 28 at midnight

- **50 mm** was recorded between
00:15 - 01:15 a.m. (1-hour record)
- **70 mm** in two hours (2-hour record)
- **100 mm** in 24-hour

- **65 mm**: average precipitation for the month of May
- May rain total: **201 mm** (monthly record for May)

Radar display of precipitation type

Colour	Precipitation Intensity	Weather Description
Blue	Light	Rain or snow
Cyan	Moderate	Rain or snow
Green	Heavy	Light thunderstorms and/or moderate rain showers
Yellow	Very Heavy	Moderate thunderstorms
Red	Intense	Potential flooding rains and severe thunderstorms
Magenta / Purple	Extreme	Flooding rains with severe thunderstorms

Making Sense of Radar Charts

Rainfall intensity

Radar displays spot estimates of rain amounts per hour

Example: Red has a range of 75 to 100 mm/hr

- Isolated thunderstorms
- Lines of thunderstorms

Typically, these pass over a location moderately quickly

**In the following we see this feature, also
thunderstorms that are stationary or re-form**

Radar: May 27 at 2210 (10:10 p.m.) Thunder Bay and area

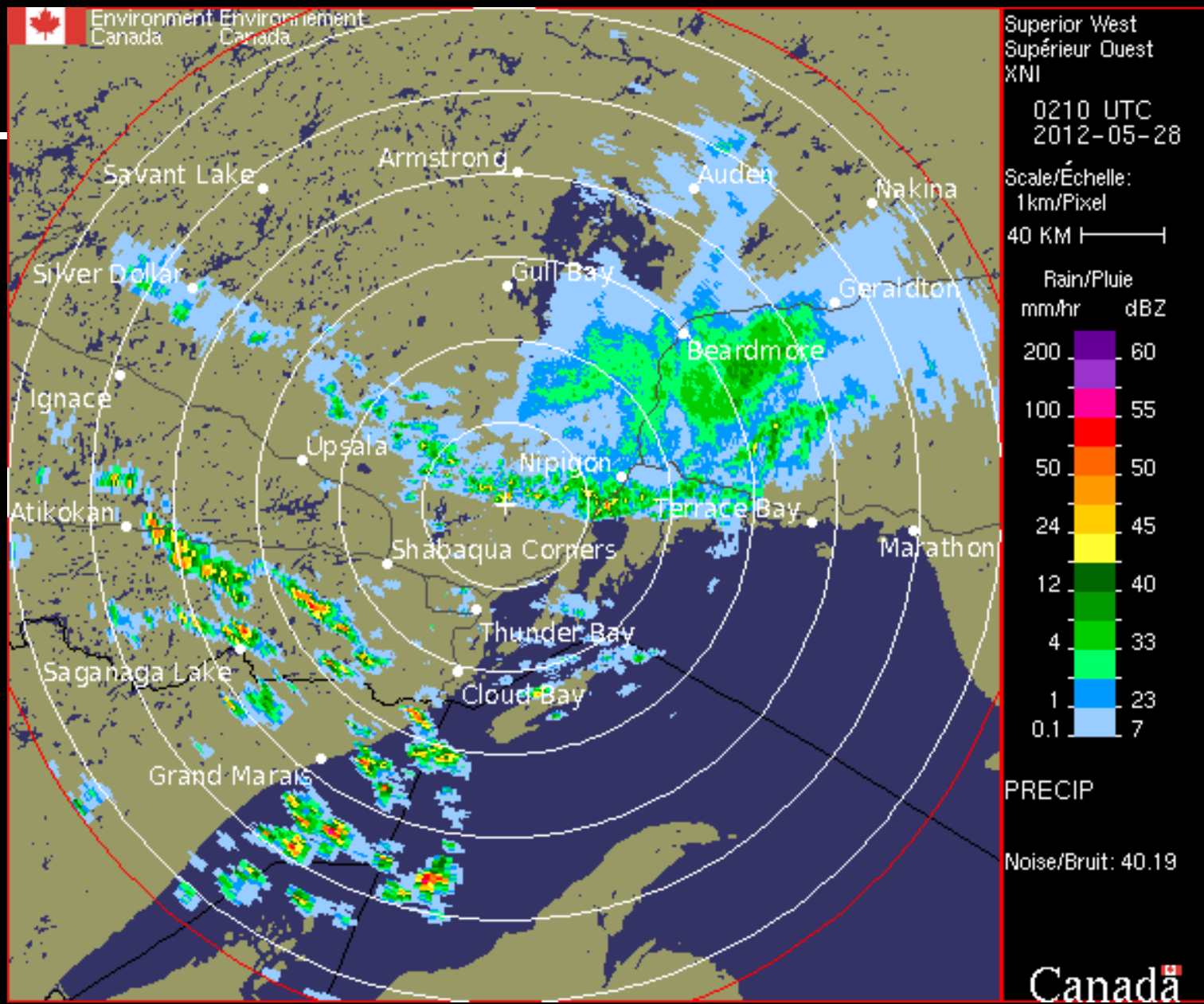

Radar May 27 at 2350 (11:50 p.m.)

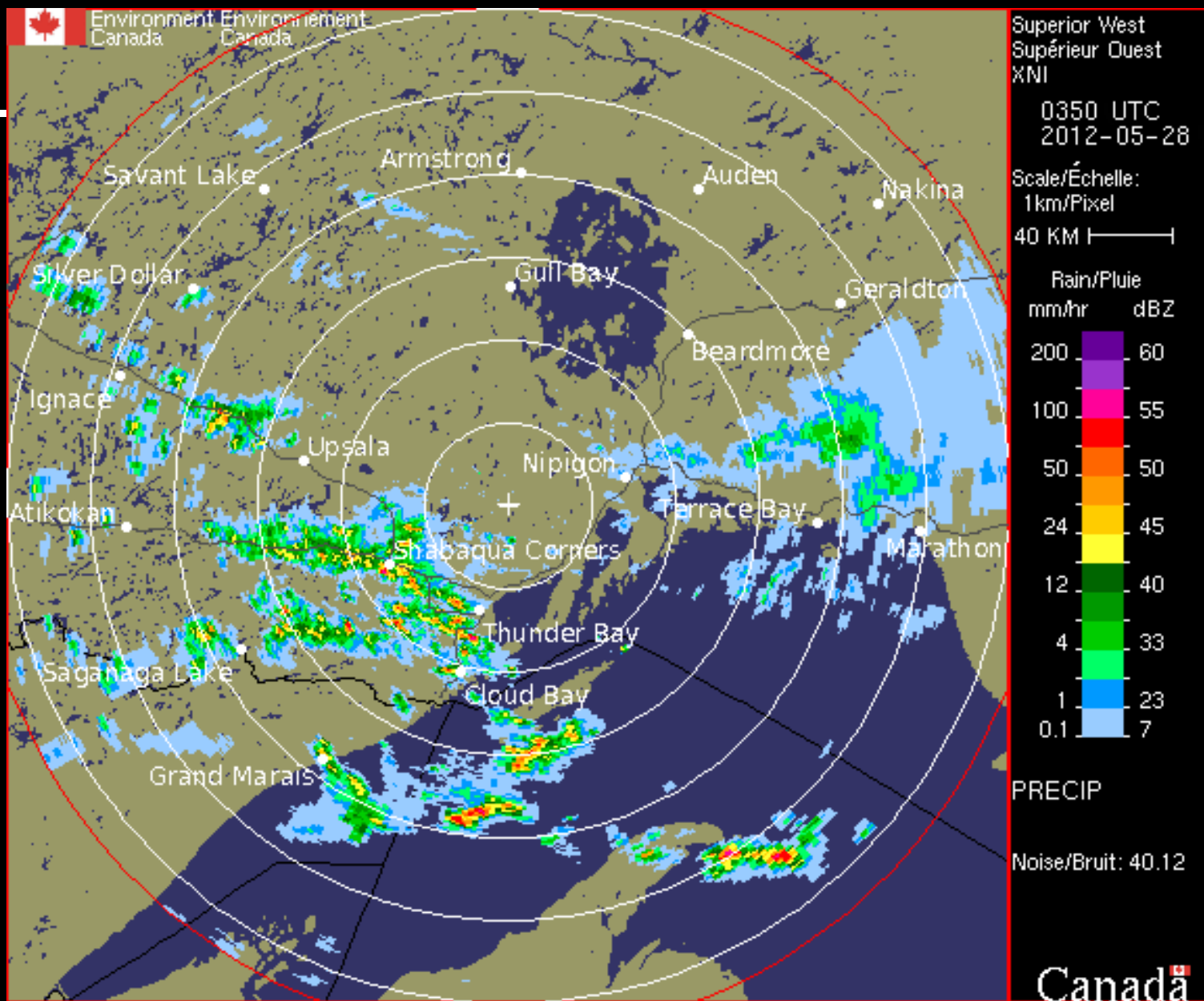

Radar: May 28 at 0010 (00:10 a.m.)

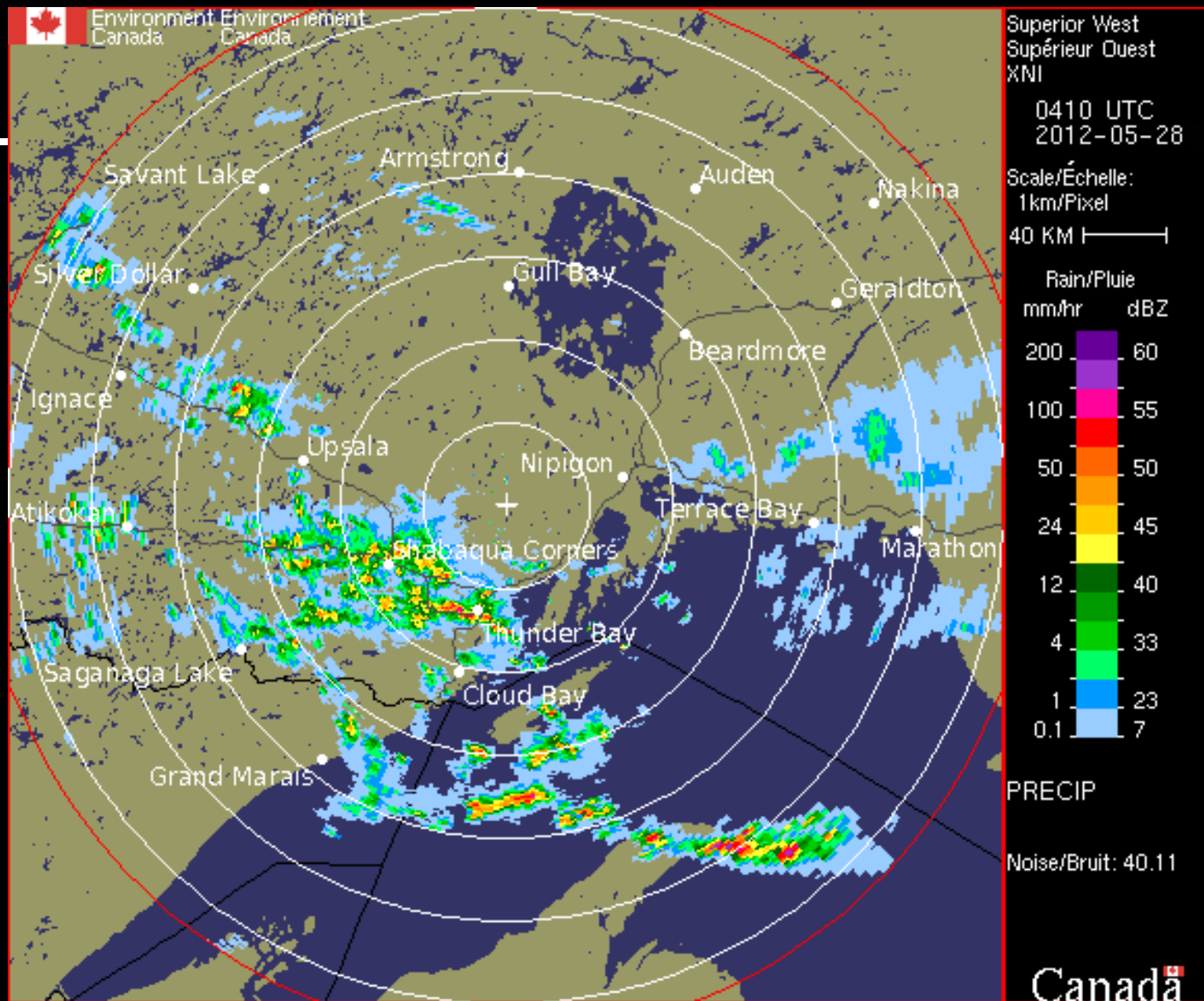

Radar: May 28 at 0010 (00:10 a.m.)



Radar: May 28 at 0030 (00:30 a.m.)



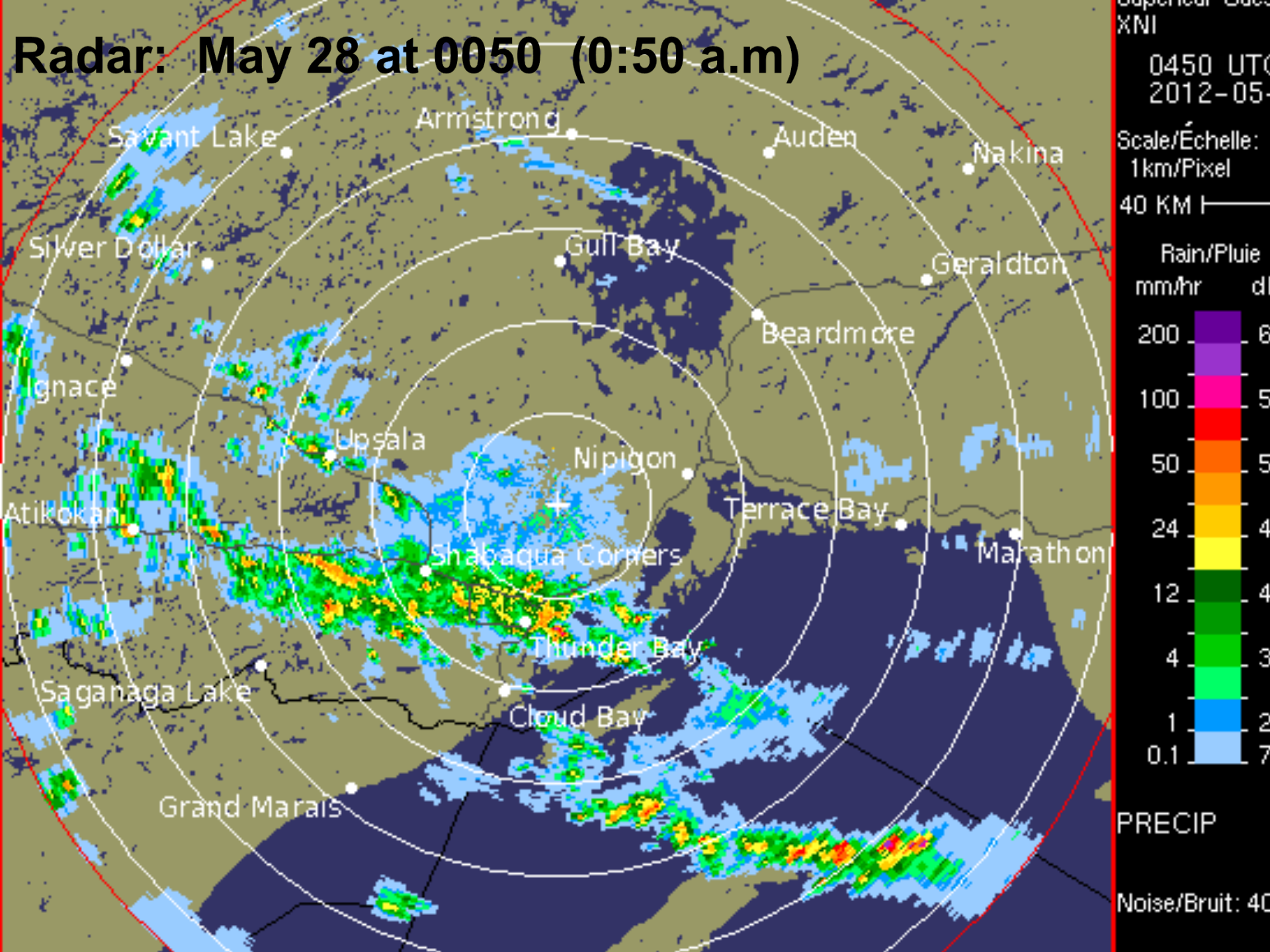

Environment Canada Warning: Severe Thunderstorms

SEVERE THUNDERSTORM WARNING, ISSUED BY ENVIRONMENT
CANADA

AT 1:27 AM EDT MONDAY 28 MAY 2012.

SEVERE THUNDERSTORM WARNING FOR:

=NEW= CITY OF THUNDER BAY

=NEW= ATIKOKAN - SHEBANDOWAN - QUETICO PARK =NEW=
SUPERIOR WEST.

==DISCUSSION==

A LINE OF NEARLY STATIONARY THUNDERSTORMS STRETCHES
ALONG HIGHWAY 11 TO THE WEST TO THUNDER BAY INTO THE CITY
OF THUNDER BAY ITSELF.

LOCAL RAINFALL AMOUNTS OVER 50 MM ARE EXPECTED BEFORE THE
HEAVIEST RAIN TAPERS OFF IN THE NEXT HOUR OR TWO. HOWEVER,
MORE RAIN IS STILL EXPECTED DURING THE NIGHT AND MONDAY. ...

Radar: May 28 at 0210 (2:10 a.m)

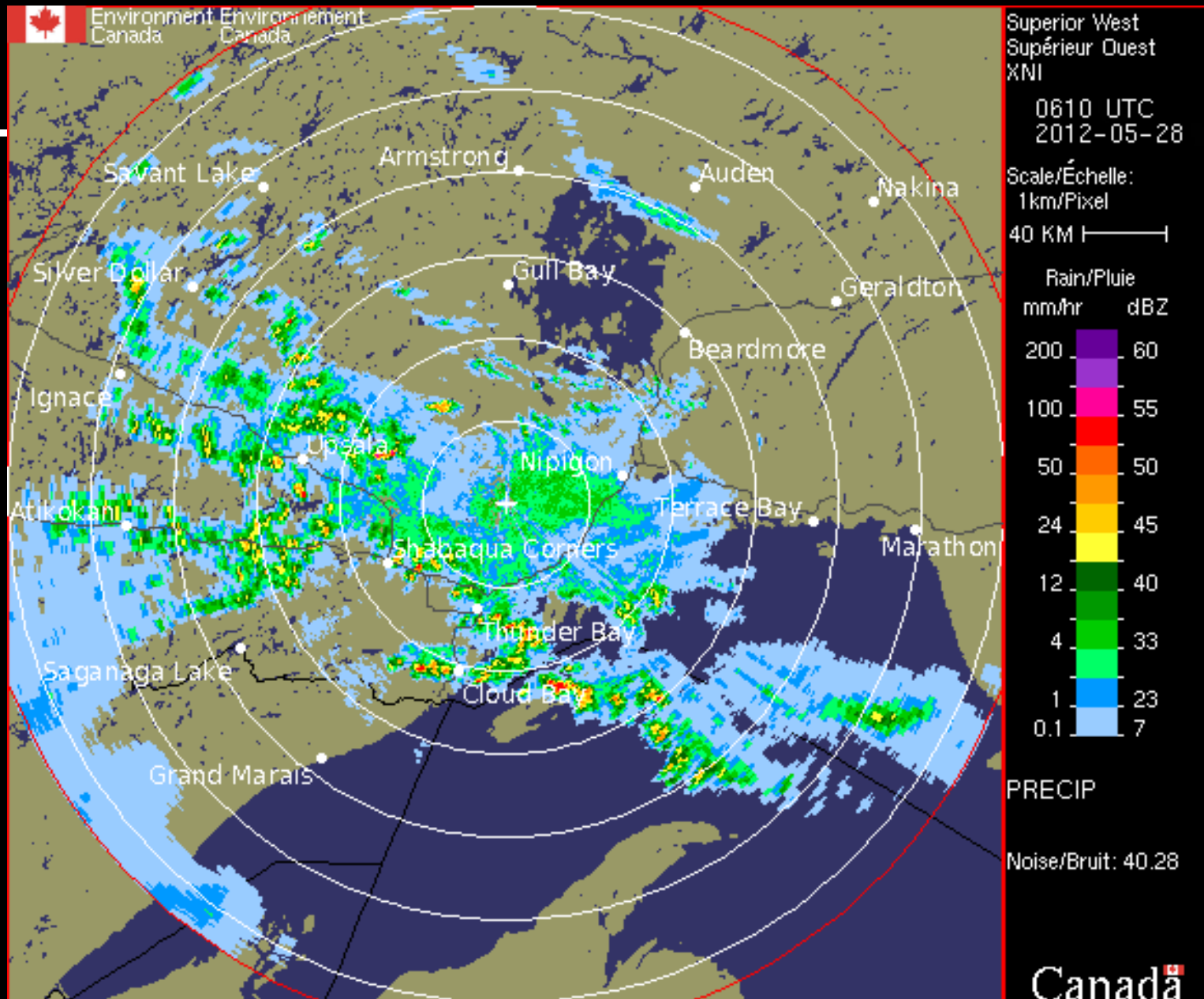

Radar: May 28 at 0410 (4:10 a.m.)

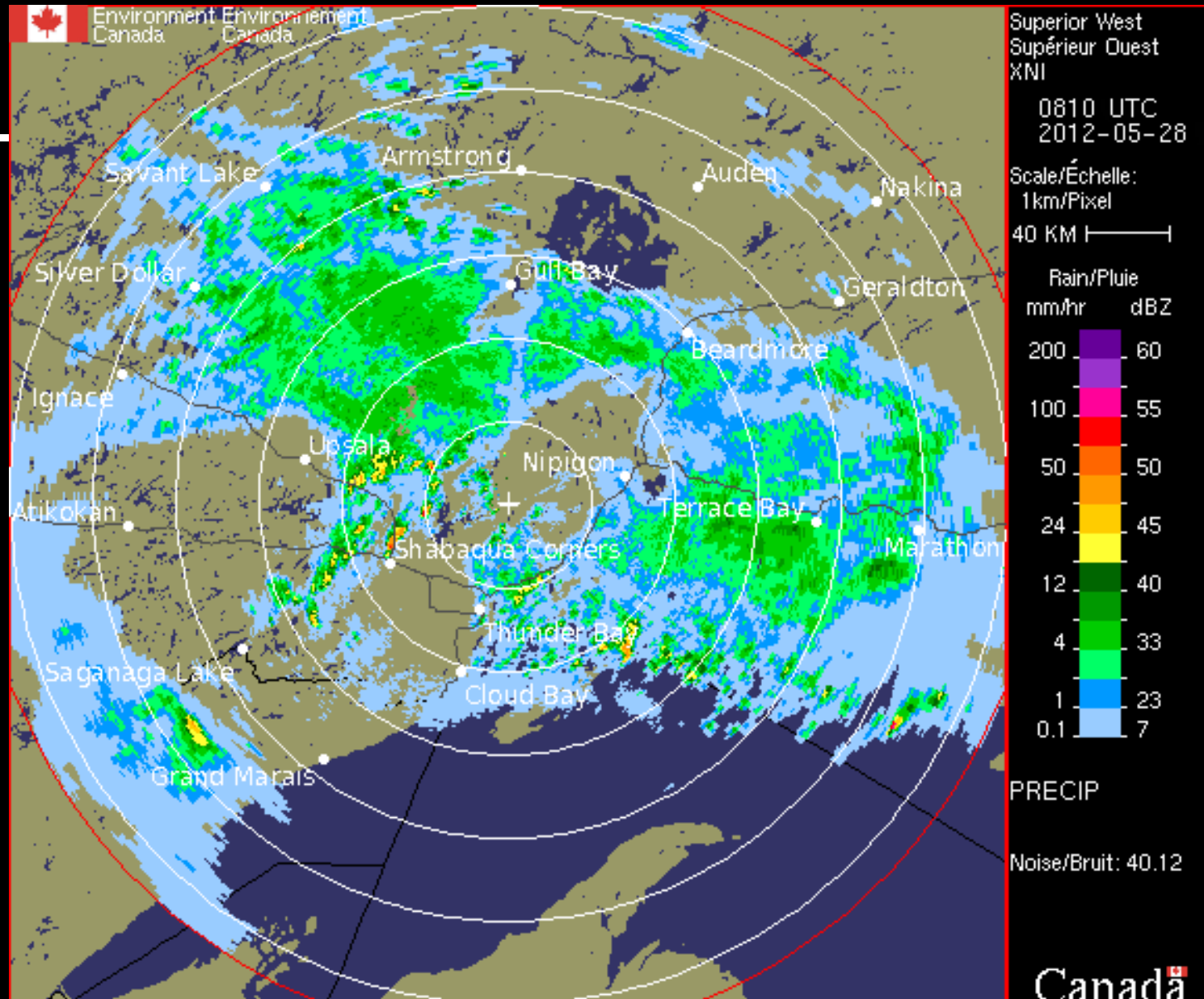

Antecedent Moisture Conditions

May 1 to 22: featured average rainfall

May 24: Heavy rain day
(50 to 60 mm measured)

May 25 to 27: 5 to 25 mm

Overland (surface) water flow

Thunder Bay Airport Intensity Duration Frequency

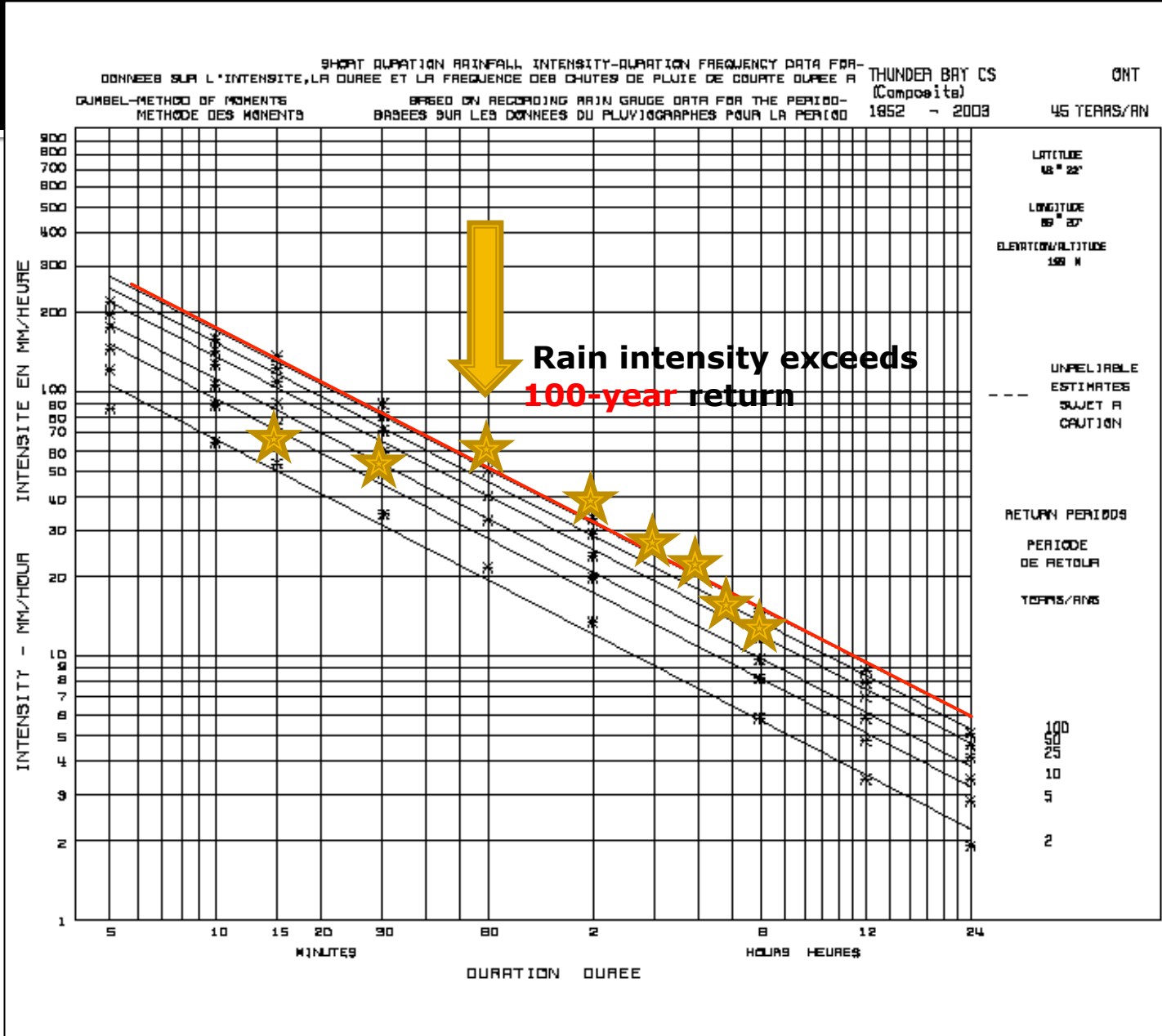

Rainfall Measurements

Problems and potential errors especially with heavy rain events equal to or greater than 75 millimetres.

- Rain gauge location
- Wind
- Mechanical errors

Rain totals tend to under report actual amounts.

Thunder Bay Historical Storms

Date	24 Hour Total (mm)	Average Rate (mm/hour)	Antecedent (mm)
Sept. 10, 1961	98.0	4.4	12.0
May 24, 1971	76.2	3.2	54.1
Sept. 26, 1973	87.1	5.8	4.9
Sept. 8, 1977	131.2	5.5	3.7
June 28, 1996	87.7	8.0	2.0
July 2, 1997	80.4	4.0	25.6
June 6, 2008	78.8	6.1	8.0
May 28, 2012	91.3	20.3	66.4
May 20-21, 2013 55 to 83			
June 25, 2016 80 to 84			
Nov. 28, 2016 78			

Average hourly rate: Total divided by storm duration (see page 22)

Atlantic Avenue WPCP Flooding Assessment

December 3, 2012



CIMA
Partners in excellence

Source of Flooding

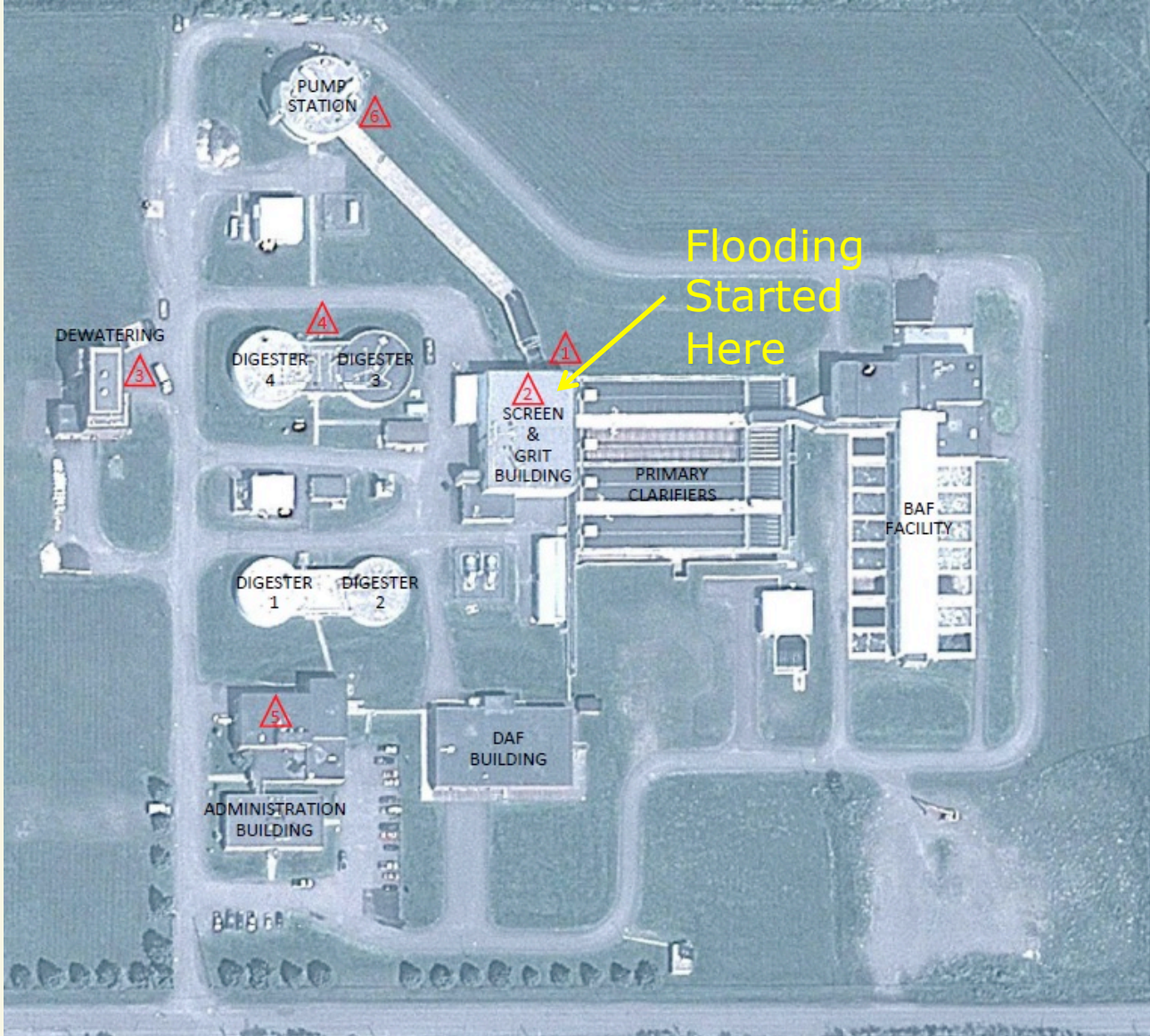

Source of Flooding

- Flooding started in Preliminary Treatment Building and progressed to all other tunnels around the plant including ultimately pump station dry well
 - Suggests excessive plugging and headloss across influent screens
 - Direction of door buckling confirms flooding from main level in Headworks down into tunnel



Estimated Plant Flows

- All flow to plant is through an on-site pumping station
 - Design capacity 766 ML/d
 - Equipped with 5 pumps (4 duty)
- Plant flow meter is calibrated to a maximum of 668 ML/d
- Applied first principles engineering approach using wet well level and manufacturer pump data to estimate flow from station

Normal Dry Weather Plant Flow

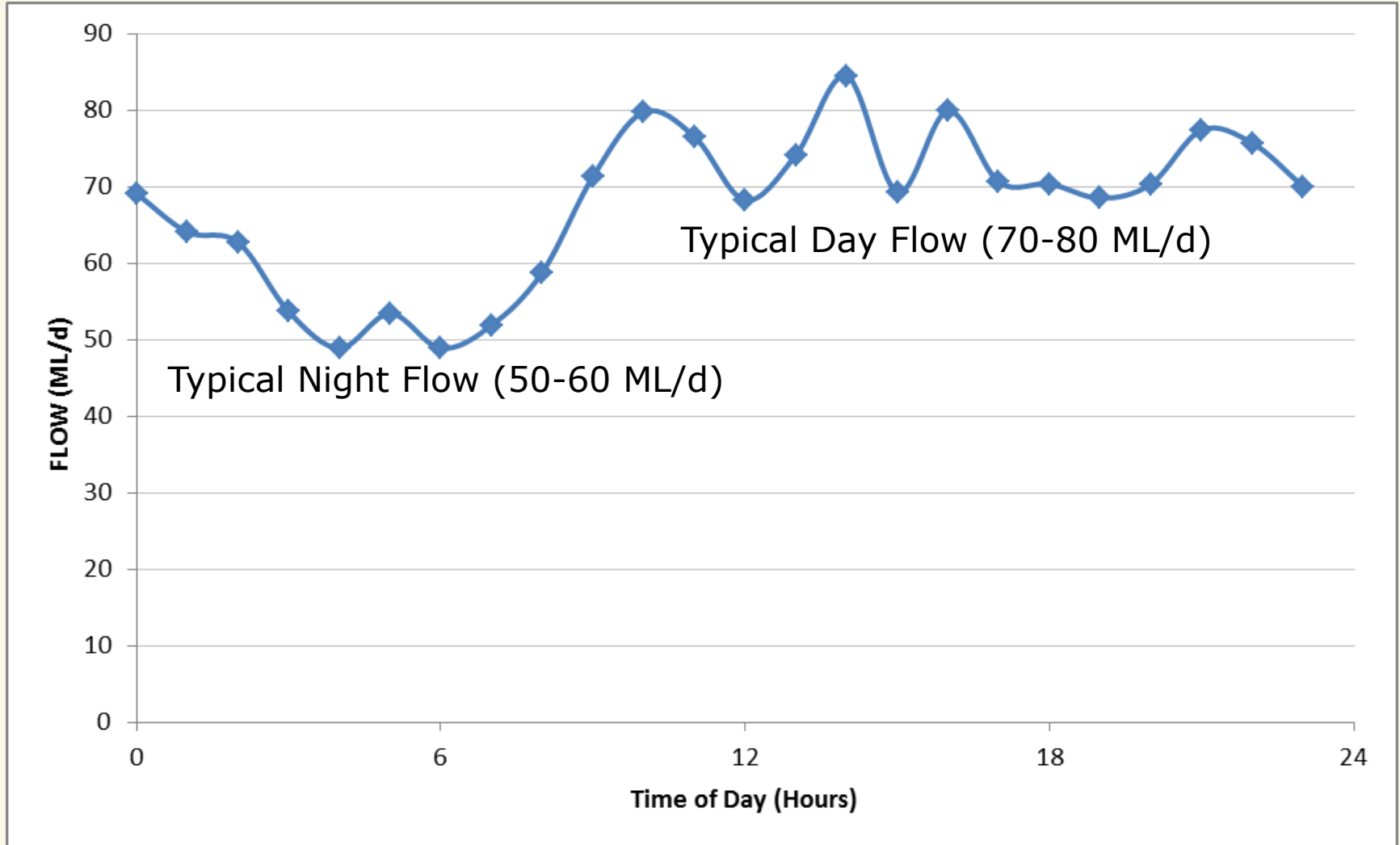

Plant Flow During Flooding (May 28, 2012)

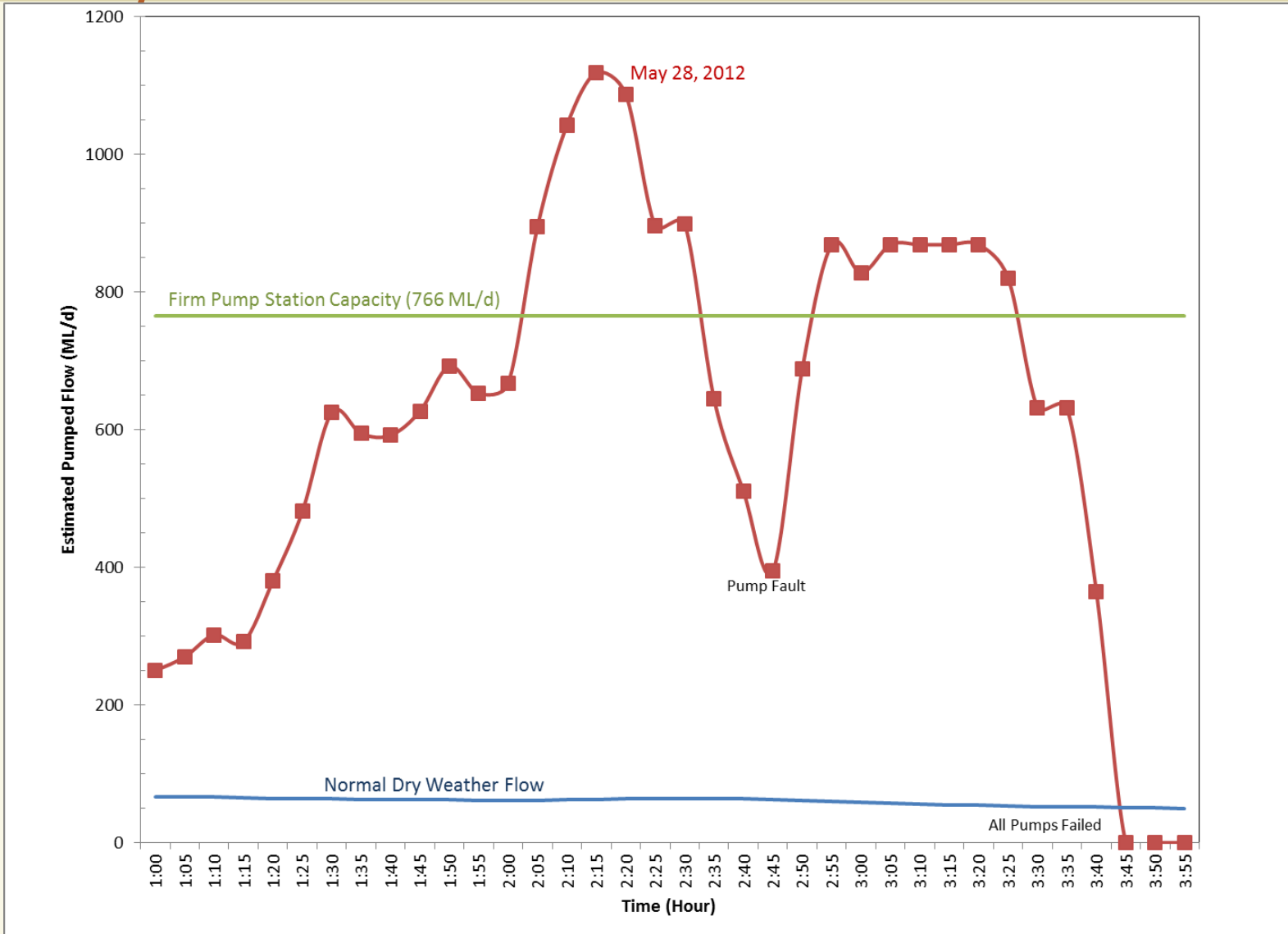

May 28th Plant Flow

- Estimated flow to the plant exceeded 1000 ML/d (more than 30% greater than station firm capacity)
- Average pump station output from 2 am to 3:30 am (before drywell flooding) approximately 800 ML/d
 - Greater than station design capacity
 - Unable to maintain normal pump station operating level due to incoming flow exceeding station capacity

GLOBAL
FORECASTING
INSTITUTE

According to this report,
climate change may cause
serious flooding!
Well, we'll cross that bridge
when we come to it.



Why Wait?

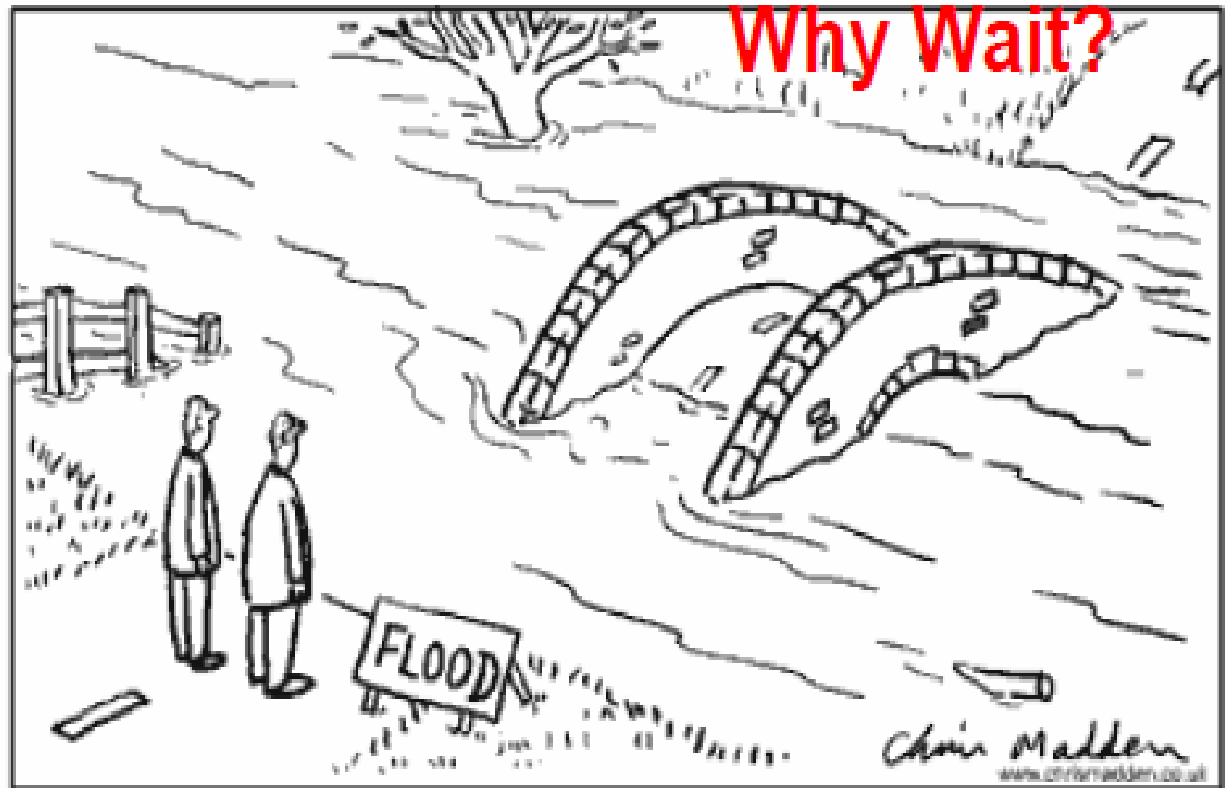

Questions and Discussion



RADAR



Radar interpretation

RADAR: RADio Detecting And Ranging

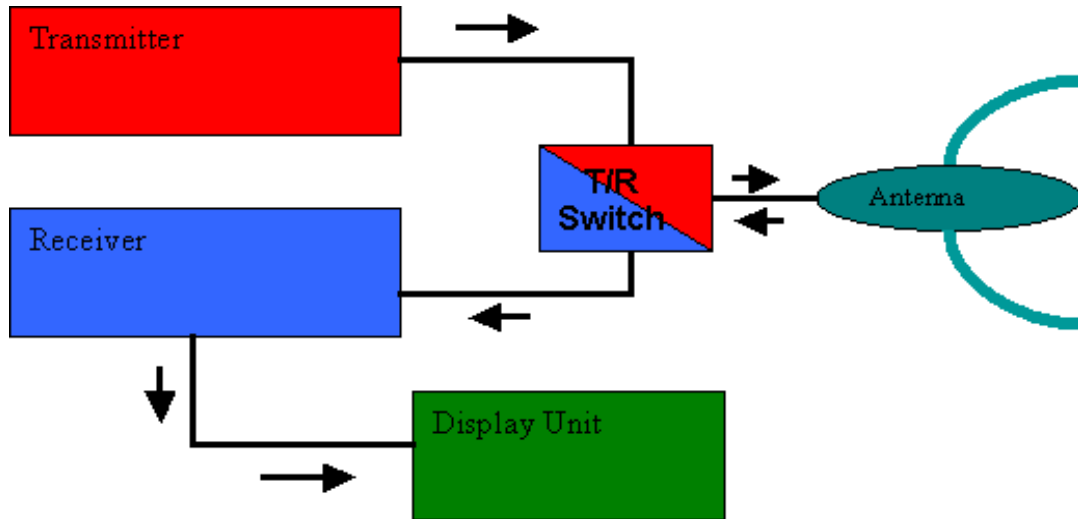

- History
- Radar science
 - Reflectivity
 - Doppler
 - Images

Radar interpretation

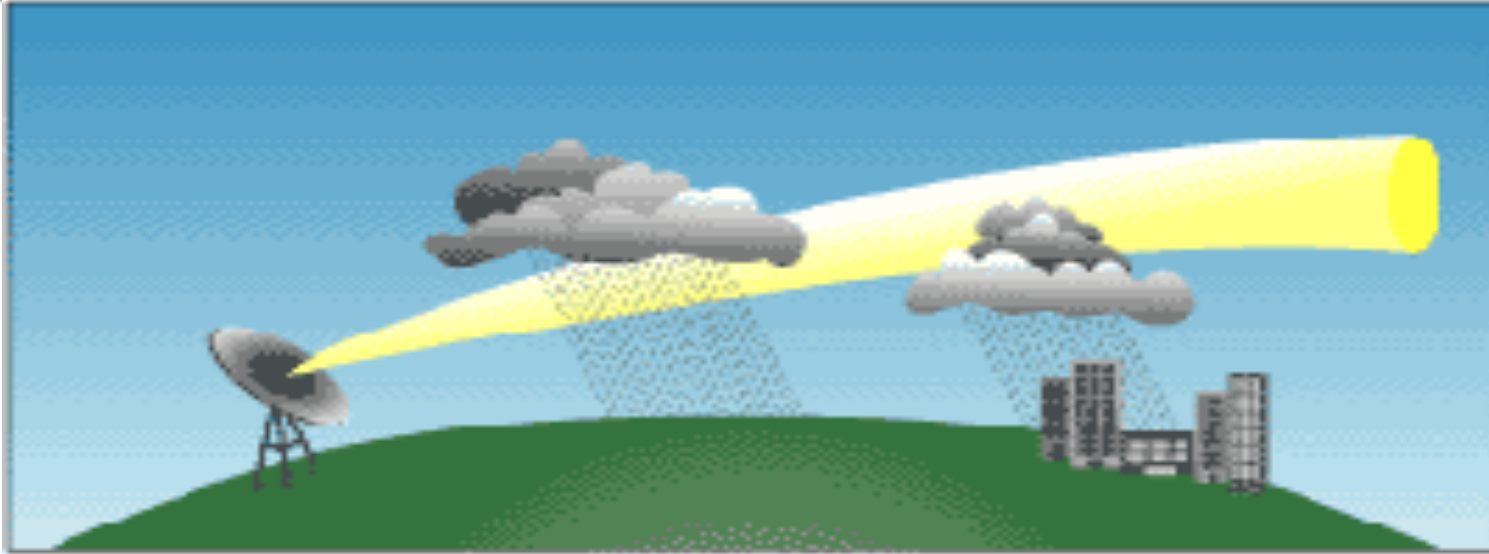

Effects of curvature of the Earth on weather radar

- Distance from the radar = returned echo becomes weaker
- **Radar Errors**
 - "ground clutter", geese, insects, bats